

- Shock IEPE Accelerometer
- Shear design
- Piezoelectric ceramic PZT-5
- Range ±10000g
- Mass – 6grams
- 10-32UNF top entry connector
- 10-32UNF Tapped base

The VS-10K is an IEPE shock accelerometer offering dedicated shock measurement capability. With a ±10000g range the VS-10K combines the flexibility of IEPE (Integrated Electronics Piezoelectric) technology with the reliability of a robust titanium fully welded construction.

Kemo can also offer cables and signal conditioning solutions for use with their full range of accelerometers.

Specification	Metric	Imperial
Sensitivity	0.05mV/(m/s <sup>2</sup> )	0.5mV/g
Measurement Range (pk)	±98000m/s <sup>2</sup>	±10000g
Frequency Range ±10%	1 to 9000 Hz	
Resonant Frequency	≥30 kHz	
Non-Linearity	≤1 %	
Transverse Sensitivity	≤5 %	
Overload Limit (Shock)	±117,600(m/s <sup>2</sup> )pk	±12000gpk
Operating Temp. Range	-40 to +85°C	-40 to +185°F
Polarity ↑	Positive	
Compliance Voltage (Supply)	+18 to +28 VDC	
Current range	2 – 10mA	
Output Bias Voltage	11VDC ± 1.5VDC	
Output Impedance	≤100Ω	
Size (excluding connector)	12.7mmA/Fx16 mm	0.50" A/Fx0.63"
Weight	6gm	0.21oz
Sensing Geometry	Shear	
Sensing Element Material	PZT-5	
Case Material	Titanium	
Connector Position	Top	
Case sealing	Hermetic	
Electrical Connection Type	10-32UNF Microdot	
Mounting	10-32UNF Tapped base for stud mount	

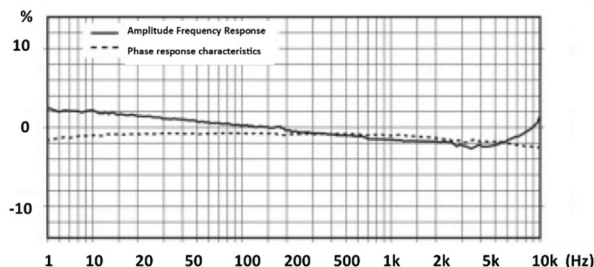
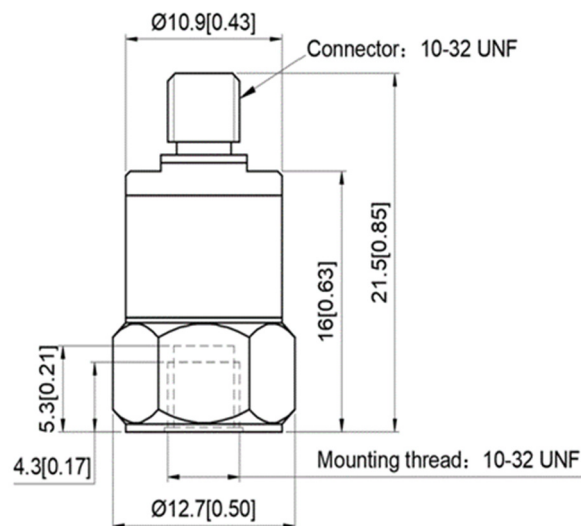

Kemo has a range of cable assemblies available for use with the VS-10K and other IEPE accelerometers.

- 1B2-30 – 3m(10ft) 10/32UNF microdot to BNC plug
- 1B2-50 – 5m(15ft) 10/32UNF microdot to BNC plug
- 1B1-30 – 3m(10ft) 10/32UNFmdot to 10/32UNFmdot
- 1B1-50 – 5m(15ft) 10/32UNFmdot to 10/32UNFmdot

### Kemo Limited

Unit 1, Dene Yard  
Green Street Green Road,  
Dartford, Kent. DA2 8DH

[www.kemo.com](http://www.kemo.com) [sales@kemo.com](mailto:sales@kemo.com)